



### Features:

- Connects inline with any 4-20mA Sensor
- Integrates hard wired sensors into wireless Voice of the Machine Software
- Does not require reprogramming of existing control system
- Definable mapping feature in Cloud to present analog signal in user defined units
- Powered by current loop eliminating need for battery
- Robust overmolded construction

### Transmitter Technical Data

Material	Polyamide Thermoplastic
Cable Length	6'
Accuracy	±1% (additive to source)
Resolution	0.03%
Minimum Supply Voltage	10V
Maximum Inputs	20mA (@ 15V)
Temperature Range	-40°F to 185°F
Certifications	FCC & IC

### Loop Analog Connector

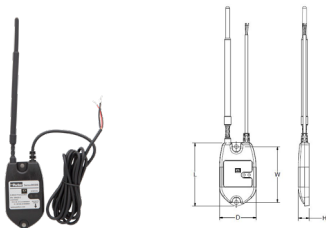

Part Number	W	D	H	L
SN422-2	2.75" [70mm]	1.81" [46mm]	.53" [13mm]	3.12" [79mm]

## SensoNODE Only Configuration

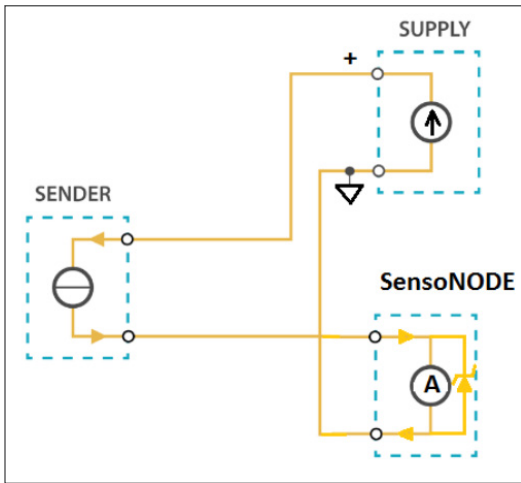

## 2 Wire Configuration

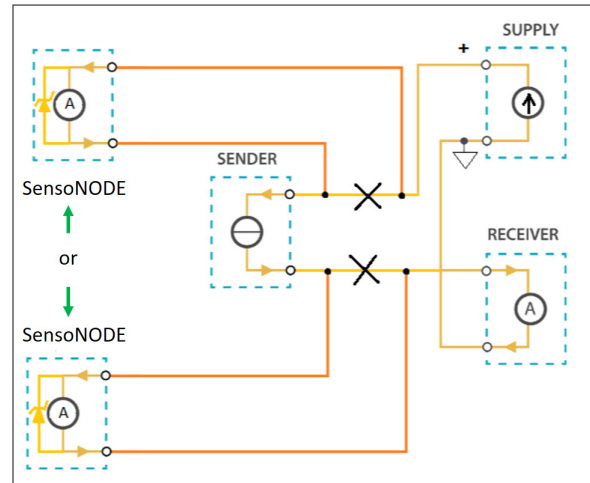

## 3 Wire Configuration

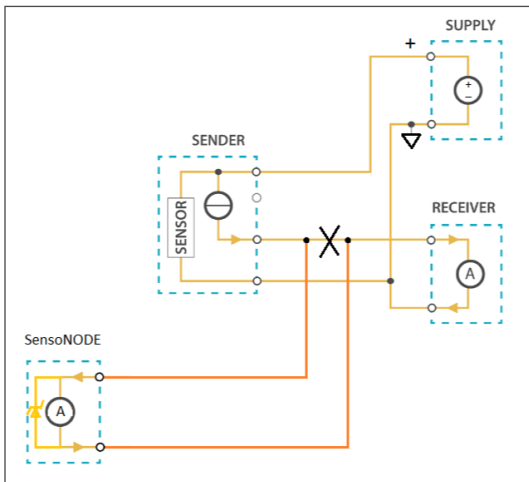

## 4 Wire Configuration

